

















 Cambiafiltro idraulico Mod. CAFI 130/220 lato estrusore  
 Hydraulic screen changer Type CAFI 130/220 extruder side  
 Changeur de filtre hydraulique Mod. CAFI 130/220 côté extrudeuse  
 Hydraulischer Filterwechsel Mod. CAFI 130/220 Extruderseite  
 Cambiador de filtro hidráulico Mod. CAFI 130/220 lado extrusora  
 Trocador de filtro hidráulico Mod. CAFI 130/220 lado extrusora  
 Гидравлический блок смены фильтра типа CAFI 130/220 вид со стороны экструдера.  
 وحدة فلتير هيدروليكية طراز CAFI 130/220



 Cambia filtro idraulico Mod. CAFI 160/250 doppio  
 Hydraulic screenchanger type CAFI 160/250 double  
 Changeur de filtre hydraulique Mod. CAFI 160/250 double  
 Hydraulischer Kassetensiebwechsler Type 160/250 zweifach  
 Cambiador de filtro hidráulico Mod. CAFI 160/250 double  
 Trocador de filtro hidráulico Mod. CAFI 160/250 double  
 Двойной гидравлический блок смены фильтра, тип CAFI 160/250  
 مبدل فلتير مزدوج هيدروليكي طراز CAFI 160/250











 Taglio in testa verticale Mod. TTC con produzioni 150 - 250 - 400 - 700 - 1000 - 1500 Kg/h  
 Vertical die face cutter Type TTC with output 150 - 250 - 400 - 700 - 1000 - 1500 Kg/h  
 Coupe en tête vertical Mod. TTC avec débits 150 - 250 - 400 - 700 - 1000 - 1500 Kg/h  
 Heissabschlaggranulator senkrecht Mod. TTC stundenleistung 150 - 250 - 400 - 700 - 1000 - 1500 Kg/h  
 Corte en cabeza vertical Mod. TTC para producir 150 - 250 - 400 - 700 - 1000 - 1500 Kg/h  
 Corte na cabeça a água vertical Mod. TTC con produções 150 - 250 - 400 - 700 - 1000 - 1500 Kg/h  
 Вертикальная головка дискового типа ТТС производительностью 250 - 400 - 700 - 1000 - 1500 кг/час  
 رأس قاطع عمودي طراز TTC بطاقة انتاجية 150-250-400-700-1000-1500 كغ/ساعة

 Taglio in testa orizzontale Mod. TTC/OR con produzioni 700 - 1000 - 1500 Kg/h  
 Horizontal die face cutter Type TTC/OR with output 700 - 1000 - 1500 Kg/h  
 Coupe en tête horizontal Mod. TTC/OR avec débits 700 - 1000 - 1500 Kg/h  
 Heissabschlaggranulator waagrecht Mod. TTC/OR stundenleistung 700 - 1000 - 1500 Kg/h  
 Corte en cabeza horizontal Mod. TTC/OR para producir 700 - 1000 - 1500 Kg/h  
 Corte na cabeça a água horizontal Mod. TTC/OR con produções 700 - 1000 - 1500 Kg/h  
 Горизонтальная головка дискового типа TTC/OR производительностью 700 - 1000 - 1500 кг/час  
 رأس قاطع افقي طراز TTC/OR بطاقة انتاجية 700-1000-1500 كغ/ساعة





 Degasificatore naturale con ripristino automatico del materiale fuso  
 Natural degasifier with automatic restoration of the melted material  
 Degasificateur naturel avec réarmement automatique de matière en fusion  
 Natürlich entgaser mit automatischer Rückstellung des geschmolzenen Materials  
 Degasificatore natural con reajuste automático de material fundido  
 Degasificadora natural com rearme automático do material fundido  
 Узел естественной дегазации с автоматическим восстановлением расплава  
 وحدة طرد طبيعية للغازات مع استعادة تلقائية للمواد المنصهرة



 Taglio in testa orizzontale Mod. TTC/OR/SP con produzioni 250 - 400 - 700 - 1000 - 1500 Kg/h  
 Horizontal die face cutter Type TTC/OR/SP with output 250 - 400 - 700 - 1000 - 1500 Kg/h  
 Coupe en tête horizontal Mod. TTC/OR/SP avec débits 250 - 400 - 700 - 1000 - 1500 Kg/h  
 Heissabschlaggranulator waagrecht Mod. TTC/OR/SP stundenleistung 250 - 400 - 700 - 1000 - 1500 Kg/h  
 Corte en cabeza horizontal Mod. TTC/OR/SP para producir 250 - 400 - 700 - 1000 - 1500 Kg/h  
 Corte na cabeça a água horizontal Mod. TTC/OR/SP con produções 250 - 400 - 700 - 1000 - 1500 Kg/h  
 Горизонтальная головка дискового типа TTC/OR/SP производительностью 250 - 400 - 700 - 1000 - 1500 кг/час  
 رأس قاطع افقي طراز TTC/OR/SP بطاقة انتاجية 250-400-700-1000-1500 كغ/ساعة



 Impianto completo Tipo MINI/60 per recupero foglia LDPE - HDPE - PP. Prod. 120/150 Kg/h.  
 Complete plant type MINI/60 suitable for recycling of LDPE - HDPE - PP sheet. Output 120/150 Kg/h.  
 Ligne complète Mod. MINI/60 pour récupération de feuille LDPE - HDPE - PP. Débit 120/150 Kg/h.  
 Kompl. Anlage Typ MINI/60 zur Rückgewinnung von Folien aus LDPE - HDPE - PP und einer. Produktionsleistung von 120/150 Kg/Std.  
 Equipo completo Tipo MINI/60 para recuperación lámina LDPE - HDPE - PP. Prod. 120/150 Kg/h.  
 Equipamento completo Tipo MINI/60 para recuperação lâmina LPDE - HDPE - PP. Prod. 120/150 Kg/h.  
 Комплектная линия типа MINI/60 для регрануляции LDPE - HDPE - PP пленок. Производительность 120-150 кг/час.  
 خط كامل طراز MINI/60 مناسب لإعادة تدوير شرائح ال LDPE - HDPE - PP بطاقة الانتاجية 120/150 كغ/ساعة











 Linea Master Mod. ES 60N/36D - DEG.  
 Master line Type ES 60N/36D - DEG.  
 Ligne Master Mod. ES 60N/36D - DEG.  
 Master-Linie Mod. ES 60N/36D - DEG.  
 Linea Master Mod. ES 60N/36D - DEG.  
 Линия для производства мастербэтч типа ES 60N/36D с дегазацией  
 خط رئيسي طراز ES 60N/36D - DEG



 Linea Master Mod. ES 60N/36D - DEG.  
 Master line Type ES 60N/36D - DEG.  
 Ligne Master Mod. ES 60N/36D - DEG.  
 Master-Linie Mod. ES 60N/36D - DEG.  
 Linea Master Mod. ES 60N/36D - DEG.  
 Линия для производства мастербэтч типа ES 60N/36D с дегазацией  
 خط رئيسي طراز ES 60N/36D - DEG



 Impianto recupero rifili in linea Mod. RIFIL/TTA - prod. 40/45 Kg/h velocità da 0 a 100 m/min.  
 Plant in-line reclaiming Type RIFIL/TTA - output 40/45 Kg/h speed from 0 to 100 m./min.  
 Installation récupération en ligne de cartouche de stylo Mod. RIFIL/TTA - prod. 40/45 Kg/h vitesse de 0 à 100 m./min.  
 Anlage verwerten randstreifen in Linie Mod. RIFIL/TTA - herstellung: 40/45 Kg/h aufwicklungsgeschwindigkeit von 0 bis 100 m./min.  
 Equipo recuperación en línea de refilos Mod. RIFIL/TTA - prod. 40/45 Kg/h velocidad de 0 a 100 m./min.  
 Equipamento de recuperação em linha de refilos Mod. RIFIL/TTA - prod. 40/45 Kg/h velocidade de 0 a 100m./min.  
 Встроенная установка регрануляции типа RIFIL/TTA. Производительность 40/45 кг/час. Скорость от 0 до 100 м/мин.  
 وحدة إعادة تدوير على الخط طراز RIFIL/TTA بطاقة الانتاجية 40/45 كغ/ساعة وسرعة من 0 لـ 100 م/د.

 Impianto recupero rifili in linea Mod. RIFIL/TTA Prod. 40/45 Kg/h. velocità da 0 a 100 m./min.  
 Plant in-line reclaiming Type RIFIL/TTA Output 40/45 Kg/h. speed from 0 to 100 m./min.  
 Installation récupération en ligne de cartouche de stylo Mod. RIFIL/TTA Débit 40/45 Kg/h. vitesse de 0 à 100 m./min.  
 Anlage verwerten Randstreifen in Linie Mod. RIFIL/TTA Herstellung 40/45 Kg/Std. Aufwicklungsgeschwindigkeit von 0 bis 100 m./min.  
 Equipo recuperación en línea de refilos Mod. RIFIL/TTA Prod. 40/45 Kg/h. velocidad de 0 a 100 m./min.  
 Equipamento de recuperação em linha de refilos Mod. RIFIL/TTA Prod. 40/45 Kg/h velocidade de 0 a 100m./min.  
 Встроенная установка регрануляции типа RIFIL/TTA. Производительность 40/45 кг/час. Скорость от 0 до 100 м/мин.  
 وحدة إعادة تدوير على الخط طراز RIFIL/TTA بطاقة الانتاجية 40/45 كغ/ساعة وسرعة من 0 لـ 100 م/د.

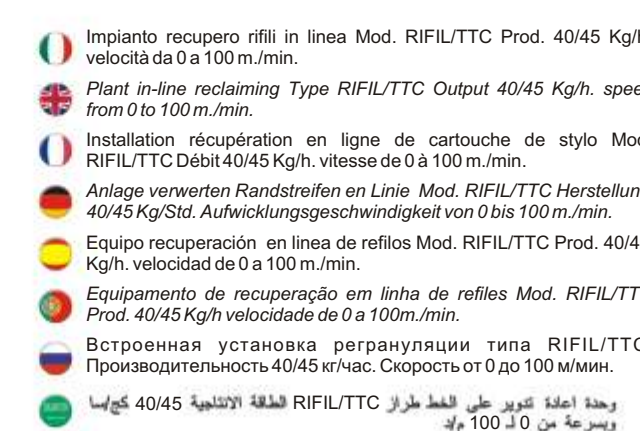

 Impianto completo Mod. ES 105/36D - FTTC per film LDPE/HDPE/PP - produzione 270/350 kg/h  
 Complete plant Type ES 105/36D - FTTC for film LDPE/HDPE/PP - output: 270/350 kg/h  
 Installation complet Mod. ES 105/36D - FTTC pour film LDPE/HDPE/PP - production horaire: 270/350 kg  
 Anlage complet Mod. ES 105/36D - FTTC - für film LDPE/HDPE/PP - Stundenleistung: 270/350 kg  
 Equipo completo Mod. ES 105/36D - FTTC Para film LDPE/HDPE/PP - Produccion Horaria: 270/350 kg  
 Комплектная линия регцилинга ES 105/36D - FTTC для пленок ПВД/ПНД/ПП производительностью 270/350 кг/час  
 خط انتاج متكامل نوع ES 105/36D - FTTC بطاقة الانتاجية من 270 الى 350 كغ/ساعة



 Impianto completo recupero scarti P.E.T. macinati con estrusore Mod. ES 105N/33D - DEG. Produzione 350 Kg/h.  
 Complete recycling plant for P.E.T. grounded scraps with extruder Type ES 105N/33D - DEG. Output 350 Kg/h.  
 Installation complète de recyclage déchets de P.E.T. broyés avec extrudeuse Mod. ES 105N/33D - DEG. Débit 350 Kg/h.  
 Komplette Wiederverwertungsanlage für Fabrikationsabfälle aus P.E.T Extruder Mod. ES 105/33D - DEG. mit Entgasung zum mahlen des Materials. Stundenleistung 350 Kg/Std.  
 Equipamento completo para recuperar desperdicio de P.E.T. transformado com extrusora Mod. ES 105N/33D - DEG. Produção 350 Kg/h.  
 Equipamento completo para recuperar desperdício P.E.T. moído com extrusora Mod. ES 105N/33D - DEG. Produção 350 Kg/h.  
 خط إعادة تدوير كامل لتفريات ال PET مع اكسترودر طراز ES 105N/33D - DEG. الطاقة الانتاجية 350 كغ/ساعة

 Impianto completo di rigenerazione a spaghetti Mod. ES 105N/33D-FN per monofilamento - multifilamento - reti di PA - PA 6 - PA6.6 - PA 6.10 - PA 6.12 - PET - PP - Prod. 300/400 Kg/h  
 Complete strands recycling plant Type ES 105N/33D-FN for monofilament - multifilament - net of PA - PA 6 - PA 6.6 - PA 6.10 - PA 6.12 - PET - PP - Output 300/400 Kg/h  
 Installation complète de régénération à spaghetti Mod. ES 105N/33D-FN pour monofilament - multifilament - réseaux de PA - PA 6 - PA 6.6 - PA 6.10 - PA 6.12 - PET - PP - Débit 300/400 Kg/h  
 Komplette Regranulier Anlage mit Stranggranulierung Modell ES 105N/33D-FN für Monofilamente Multifilamente - Gewebe aus PA - PA 6 - PA 6.6 - PA 6.10 - PA 6.12 - PET - PP - Produktionsleistung von 300/400 Kg/Std  
 Equipo completo de regeneración a spaguetti Mod. ES 105N/33D-FN para monofilamento - multifilamento - redes de PA - PA 6 - PA 6.6 - PA 6.10 - PA 6.12 - PET - PP - Producción 300/400 Kg/h  
 Equipamento completo de recuperação tipo esparguete Mod. ES 105N/33D-FN para monofilamento multifilamento - redes de PA - PA 6 - PA 6.6 - PA 6.10 - PA 6.12 - PET - PP - Produção 300/400 Kg/h  
 Комплектная линия ES 105/33D-FN для рецилинга сеток из мононитей - мультинитей ПА - ПА6 - ПА6.6 - ПА6.10 - ПА6.12 - ПЭТФ - ПП с производительностью 300 - 400 кг/час  
 خط انتاج متكامل نوع ES 105/33D-FN للشبكات احمية أو متعددة الفيويد والمصنعة من 300 الى 400 كغ/ساعة

 Impianto completo di rigenerazione a spaghetti Mod. ES 105N/33D-FN per monofilamento - multifilamento - reti di PA - PA 6 - PA6.6 - PA 6.10 - PA 6.12 - PET - PP - Prod. 300/400 Kg/h  
 Complete strands recycling plant Type ES 105N/33D-FN for monofilament - multifilament - net of PA - PA 6 - PA 6.6 - PA 6.10 - PA 6.12 - PET - PP - Output 300/400 Kg/h  
 Installation complète de régénération à spaghetti Mod. ES 105N/33D-FN pour monofilament - multifilament - réseaux de PA - PA 6 - PA 6.6 - PA 6.10 - PA 6.12 - PET - PP - Débit 300/400 Kg/h  
 Komplette Regranulier Anlage mit Stranggranulierung Modell ES 105N/33D-FN für Monofilamente Multifilamente - Gewebe aus PA - PA 6 - PA 6.6 - PA 6.10 - PA 6.12 - PET - PP - Produktionsleistung von 300/400 Kg/Std  
 Equipo completo de regeneración a spaguetti Mod. ES 105N/33D-FN para monofilamento - multifilamento - redes de PA - PA 6 - PA 6.6 - PA 6.10 - PA 6.12 - PET - PP - Producción 300/400 Kg/h  
 Equipamento completo de recuperação tipo esparguete Mod. ES 105N/33D-FN para monofilamento multifilamento - redes de PA - PA 6 - PA 6.6 - PA 6.10 - PA 6.12 - PET - PP - Produção 300/400 Kg/h  
 Комплектная линия ES 105/33D-FN для рецилинга сеток из мононитей - мультинитей ПА - ПА6 - ПА6.6 - ПА6.10 - ПА6.12 - ПЭТФ - ПП с производительностью 300 - 400 кг/час  
 خط انتاج متكامل نوع ES 105/33D-FN للشبكات احمية أو متعددة الفيويد والمصنعة من 300 الى 400 كغ/ساعة

 Impianto completo Mod. ES 105/36D - FTTC per film LDPE/HDPE/PP - produzione 270/350 kg/h  
 Complete plant Type ES 105/36D - FTTC for film LDPE/HDPE/PP - output: 270/350 kg/h  
 Installation complet Mod. ES 105/36D - FTTC pour film LDPE/HDPE/PP - production horaire: 270/350 kg  
 Anlage complet Mod. ES 105/36D - FTTC - für film LDPE/HDPE/PP - Stundenleistung: 270/350 kg  
 Equipo completo Mod. ES 105/36D - FTTC Para film LDPE/HDPE/PP - Produccion Horaria: 270/350 kg  
 Комплектная линия регцилинга ES 105/36D - FTTC для пленок ПВД/ПНД/ПП производительностью 270/350 кг/час  
 خط انتاج متكامل نوع ES 105/36D - FTTC بطاقة الانتاجية من 270 الى 350 كغ/ساعة



 Impianto completo Mod. ES 105/36D - FTTC per film LDPE/HDPE/PP - produzione 270/350 kg/h  
 Complete plant Type ES 105/36D - FTTC for film LDPE/HDPE/PP - output: 270/350 kg/h  
 Installation complet Mod. ES 105/36D - FTTC pour film LDPE/HDPE/PP - production horaire: 270/350 kg  
 Anlage complet Mod. ES 105/36D - FTTC - für film LDPE/HDPE/PP - Stundenleistung: 270/350 kg  
 Equipo completo Mod. ES 105/36D - FTTC Para film LDPE/HDPE/PP - Produccion Horaria: 270/350 kg  
 Комплектная линия регцилинга ES 105/36D - FTTC для пленок ПВД/ПНД/ПП производительностью 270/350 кг/час  
 خط انتاج متكامل نوع ES 105/36D - FTTC بطاقة الانتاجية من 270 الى 350 كغ/ساعة





 Impianto completo Mod. ES 105/36D - FTTC per film LDPE/HDPE/PP - produzione 270/350 kg/h  
 Complete plant Type ES 105/36D - FTTC for film LDPE/HDPE/PP - output: 270/350 kg/h  
 Installation complet Mod. ES 105/36D - FTTC pour film LDPE/HDPE/PP - production horaire: 270/350 kg  
 Anlage complet Mod. ES 105/36D - FTTC - für film LDPE/HDPE/PP - Stundenleistung: 270/350 kg  
 Equipo completo Mod. ES 105/36D - FTTC Para film LDPE/HDPE/PP - Produccion Horaria: 270/350 kg  
 Комплектная линия регцилинга ES 105/36D - FTTC для пленок ПВД/ПНД/ПП производительностью 270/350 кг/час  
 خط انتاج متكامل نوع ES 105/36D - FTTC بطاقة الانتاجية من 270 الى 350 كغ/ساعة

 Impianto completo Mod. ES 105/36D - FTTC per film LDPE/HDPE/PP - produzione 270/350 kg/h  
 Complete plant Type ES 105/36D - FTTC for film LDPE/HDPE/PP - output: 270/350 kg/h  
 Installation complet Mod. ES 105/36D - FTTC pour film LDPE/HDPE/PP - production horaire: 270/350 kg  
 Anlage complet Mod. ES 105/36D - FTTC - für film LDPE/HDPE/PP - Stundenleistung: 270/350 kg  
 Equipo completo Mod. ES 105/36D - FTTC Para film LDPE/HDPE/PP - Produccion Horaria: 270/350 kg  
 Комплектная линия регцилинга ES 105/36D - FTTC для пленок ПВД/ПНД/ПП производительностью 270/350 кг/час  
 خط انتاج متكامل نوع ES 105/36D - FTTC بطاقة الانتاجية من 270 الى 350 كغ/ساعة

 Impianto completo Mod. ES 105/36D - FTTC per film LDPE/HDPE/PP - produzione 270/350 kg/h  
 Complete plant Type ES 105/36D - FTTC for film LDPE/HDPE/PP - output: 270/350 kg/h  
 Installation complet Mod. ES 105/36D - FTTC pour film LDPE/HDPE/PP - production horaire: 270/350 kg  
 Anlage complet Mod. ES 105/36D - FTTC - für film LDPE/HDPE/PP - Stundenleistung: 270/350 kg  
 Equipo completo Mod. ES 105/36D - FTTC Para film LDPE/HDPE/PP - Produccion Horaria: 270/350 kg  
 Комплектная линия регцилинга ES 105/36D - FTTC для пленок ПВД/ПНД/ПП производительностью 270/350 кг/час  
 خط انتاج متكامل نوع ES 105/36D - FTTC بطاقة الانتاجية من 270 الى 350 كغ/ساعة



 Impianto completo Mod. ES 105/36D - FTTC per film LDPE/HDPE/PP - produzione 270/350 kg/h  
 Complete plant Type ES 105/36D - FTTC for film LDPE/HDPE/PP - output: 270/350 kg/h  
 Installation complet Mod. ES 105/36D - FTTC pour film LDPE/HDPE/PP - production horaire: 270/350 kg  
 Anlage complet Mod. ES 105/36D - FTTC - für film LDPE/HDPE/PP - Stundenleistung: 270/350 kg  
 Equipo completo Mod. ES 105/36D - FTTC Para film LDPE/HDPE/PP - Produccion Horaria: 270/350 kg  
 Комплектная линия регцилинга ES 105/36D - FTTC для пленок ПВД/ПНД/ПП производительностью 270/350 кг/час  
 خط انتاج متكامل نوع ES 105/36D - FTTC بطاقة الانتاجية من 270 الى 350 كغ/ساعة

 Impianto completo Mod. ES 105/36D - FTTC per film LDPE/HDPE/PP - produzione 270/350 kg/h  
 Complete plant Type ES 105/36D - FTTC for film LDPE/HDPE/PP - output: 270/350 kg/h  
 Installation complet Mod. ES 105/36D - FTTC pour film LDPE/HDPE/PP - production horaire: 270/350 kg  
 Anlage complet Mod. ES 105/36D - FTTC - für film LDPE/HDPE/PP - Stundenleistung: 270/350 kg  
 Equipo completo Mod. ES 105/36D - FTTC Para film LDPE/HDPE/PP - Produccion Horaria: 270/350 kg  
 Комплектная линия регцилинга ES 105/36D - FTTC для пленок ПВД/ПНД/ПП производительностью 270/350 кг/час  
 خط انتاج متكامل نوع ES 105/36D - FTTC بطاقة الانتاجية من 270 الى 350 كغ/ساعة