

# HiQ

The new generation of  
**ultrasonic welding technology.**

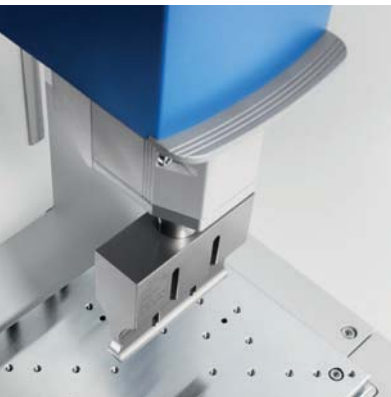

**HiQ DIALOG**  
SpeedControl



**HiQ VARIO**  
PropControl



**HiQ LOGIC**  
PropControl



**HiQ SOLID**  
PropControl



**Ultra<sup>3</sup>**  
BY HERRMANN ULTRASCHALL

- ✓ **ULTRA** PRECISE
- ✓ **ULTRA** FLEXIBLE
- ✓ **ULTRA** ECONOMICAL

## The new HiQ series. Developed to give you the edge.

It's precise, flexible and economical! Experience the wealth of innovative energy from Herrmann Ultraschall with our new generation of ultrasonic welding machines. Specific, yet versatile customer requirements are at the heart of this revolutionary series like never before. The HiQ series systems provide you with the right machine to suit your application, manufacturing environment and budget.

With this new range of machines, you can now configure your welding applications in a more targeted and individual manner. Thanks to intelligent performance classifications and different variants in the machine and software environment, the HiQ series combines complex joining technologies with user-friendly, simple handling.

Outstanding technology and excellent efficiency allow us to set new worldwide standards in ultrasonic welding technology – giving you the edge.

# HiQ DIALOG

SpeedControl



# Two times outstanding. Speed and precision.

The new HiQ DIALOG machine is equipped with a wealth of innovative features and enhancements. At the heart of this machine is the new pneumatic HMC drive system. It combines the benefits of pneumatics with the dynamics of an electrical drive, allowing the user to choose any starting point for the weld process. Supported by the SoftTouch mode, sensitive joint designs on plastic parts to be welded, are protected from impact when the sonotrode makes contact. The process-oriented user interface guarantees high usability. The standard equipment includes Ethernet, USB high-speed and printer connections. The HiQ DIALOG is one of the most powerful and benefit packed ultrasonic welding systems worldwide!



## Performance characteristics

- Intuitive weld process control: DIALOG control
- Industrial PC with Windows® XP embedded MUI
- SpeedControl: freely programmable HMC drive system
- Flexible force profiling: up to 3 programmable weld forces + hold force
- Highly precise incremental positioning measurement
- Quality monitoring with graphic display and analysis
- Energy save mode
- Safety concept: ActiveGuard
- Integrated workspace illumination

## Technical data

HiQ DIALOG	20 kHz	35 kHz
Generator output [W]	2400 / 4800 / 6200	1200
Weld force min/max* [N] *at 8 bar	30 / 2490	10 / 650
Sonotrode stroke [mm]	150	100
Machine dimensions ( w x h* x d) [mm] *at max. height setting	723 / 1533 / 707	723 / 1533 / 707
Throat depth to center of sonotrode [mm]	260	260
Height adjustment [mm]	430	430
Control panel	15"-touch screen color	15"-touch screen color
Weld modes	7	7
Number of weld memories	1000	1000
Number of welds stored (data & graphs)	300 per memory	300 per memory
Auxiliary functions (optional)	max. 6	max. 6

# HiQ VARIO

PropControl



# Flexible in every way.

## Top cost-performance ratio.

The HiQ VARIO system series is a very flexible machine that can be configured to fully satisfy the needs of the user. A variety of pneumatic drive units with various strokes and cylinder diameters are available, all of which feature Herrmann's proven proportional valve technology. Users can also choose between 3 operating frequencies as well as digital ultrasonic generators that can provide up to 6200 Watts of output power. The Unicode capability of the control panel allows menu guidance in your language, thereby enabling ease of use worldwide. The capability of utilizing various password levels secure the welding parameters against accidental or unauthorized changes. Graphic visualization of the joining process enables an operator to define the weld parameters and record the quality data during production. Finally, the secure quick change system QCS simplifies the stack changing process.



### Performance characteristics

- Powerful weld process control: VARIO control
- Graphical recording and visualization of the weld process
- Color touch control panel, Unicode-capable
- USB interfaces
- PropControl: Proportional valve technology
- Force profiling of 2 weld forces
- Precise position measuring system
- Safety concept: ActiveGuard
- Coordinated accessories and additional software available

### Technical data

HiQ VARIO	20 kHz	30 kHz	35 kHz
Generator output [W]	2400 / 4800 / 6200	1800	1200
Weld force min/max* [N] *at 8 bar	30 / 2490	30 / 1500	10 / 650
Sonotrode stroke [mm]	25 / 50 / 100 / 125	25 / 50 / 100	25 / 50 / 100
Machine dimensions ( w x h x d) [mm] *at max. height setting	678 / 1533 / 707	678 / 1533 / 707	678 / 1533 / 707
Throat depth to center of sonotrode [mm]	260	260	260
Height adjustment [mm]	430	430	430
Control panel	8,4"-touch screen color	8,4"-touch screen color	8,4"-touch screen color
Weld modes	5	5	5
Number of weld memories	32	32	32
Number of welds stored (data & graphs)	100 per memory	100 per memory	100 per memory
Auxiliary functions (optional)	max. 4	max. 4	max. 4

# HiQ LOGIC

PropControl





# The perfect mix. For a perfect introduction.

Robustness, accuracy and simplicity are the attributes that characterize this ultrasonic welding machine. This efficient all digital welding system includes premium features such as the precision measuring system and proven proportional valve technology as standard. It also includes password protection and production counters. A 5.7" touch screen allows an operator to program the system and to monitor the weld process with ease. The universal structure of the operator interface makes it extremely easy to transfer to any other Herrmann Ultraschall HiQ system. Precision guiding and proven drive components guarantee a consistent and repeatable weld process. HiQ LOGIC – the perfect introduction to the world of ultrasonic welding!



## Performance characteristics

- Solid and rigid machine structure
- Process-oriented control: LOGIC control
- Operation via unicode compatible touch panel
- USB interfaces
- PropControl: Proportional valve technology
- Reliable positioning measuring system
- Operator safety includes ergonomic 2-hand activation system

## Technical data

HiQ LOGIC	20 kHz	35 kHz
Generator output [W]	1600 / 2400 / 4800 / 6200	1200
Weld force min/max* [N] *at 8 bar	70 / 2350	20 / 590
Sonotrode stroke [mm]	25 / 50 / 100	25 / 50 / 100
Machine dimensions ( w x h* x d) [mm] *at max. height setting	638 / 1533 / 754	638 / 1533 / 754
Throat depth to center of sonotrode [mm]	260	260
Height adjustment [mm]	430	430
Control panel	5,7"-touch screen monochrome	5,7"-touch screen monochrome
Weld modes	5	5
Number of weld memories	16	16
Number of welds stored (data)	50 per memory	50 per memory
Auxiliary functions (optional)	max. 2	max. 2

# HiQ SOLID

PropControl

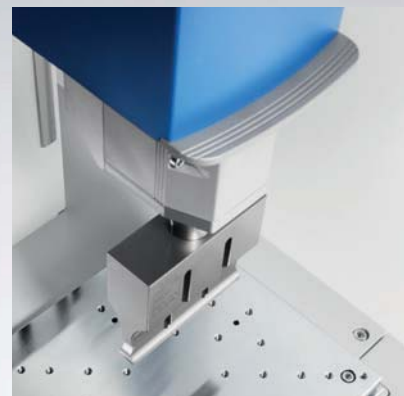

# Ultrasonic welding.

## Reduced to the essentials.

This machine is characterized by its simplicity, yet does not compromise on Herrmann Ultraschall's proven standards. Proportional valve technology and digital high-performance generators are included in every machine. A solid machine concept with precision guiding and proven drive components lay the foundation for quality and reproducible welding. Depending on the application, Herrmann Ultraschall offers two choices for this machine type. STE is the basic model, which features three welding modes, Time, Power and Energy. There is also the optional SDM component with additional distance modes for improved monitoring of the weld process. HiQ SOLID – the essentials are simple.



### Performance characteristics

- Solid and rigid machine structure
- Process-oriented control: SOLID control
- Operation via keypad with unicode compatible matrix display
- USB interface for data exchange
- PropControl: Proportional valve technology
- Reliable positioning measuring system
- Operator safety through ergonomic 2-hand activation system

### Technical data

HiQ SOLID	HiQ SDM 20 kHz	HiQ SDM 35 kHz	HiQ STE 20 kHz	HiQ STE 35 kHz
Generator output [W]	900 / 1600 / 2400 / 4800 / 6200	1200	900 / 1600 / 2400 / 4800 / 6200	1200
Weld force min/max* [N] *at 8 bar	70 / 2350	30 / 590	70 / 2350	30 / 590
Sonotrode stroke [mm]	50 / 100	50 / 100	50 / 100	50 / 100
Machine dimensions (w x h* x d) [mm] *at max. height setting	642 / 1533 / 754	642 / 1533 / 754	642 / 1533 / 754	642 / 1533 / 754
Throat depth to center of sonotrode [mm]	260	260	260	260
Height adjustment [mm]	430	430	430	430
Control panel	128 x 64 matrix monochrome	128 x 64 matrix monochrome	128 x 64 matrix monochrome	128 x 64 matrix monochrome
Weld modes	5	5	3	3
Number of weld memories	8	8	8	8

# Key technologies.

## Innovations to give you the edge.

To get ahead you need a solution that does more than simply satisfy your functional requirements. Our key technologies stand for added customer benefits, including a reduction in non-productive times, simple operation and maximum safety. Cost and energy efficiency as well as environmental protection are other key areas we are dedicated to. Our passion for ultrasonic welding technology drives us to constantly set new standards. We develop innovations to give you the edge!

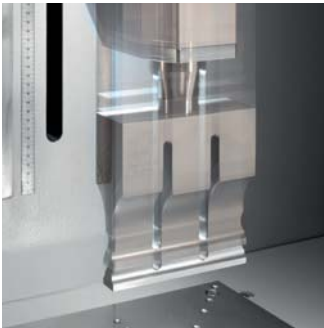

### HMC: High Motion Control

The newly developed module is a closed-loop control unit which regulates pneumatic pressure precisely. It operates based on electronic differential pressure control of the pneumatic cylinder and is active along the entire stroke range. It allows operators to control any force or position at a process-optimized movement speed with an extremely high degree of repeat accuracy. The position is determined using a non-contact incremental position measuring system with continuous referencing. Together with the pneumatic drive, this forms a freely programmable drive system for speed-optimized sonotrode movement (SpeedControl).



### QCS: Quick Change System

The quick-change system allows an indexed change of the present ultrasonic stack without time-consuming adjustments – to be accomplished accurately in seconds when changing applications.



### Energy efficiency

Ultrasonic welding technology is environmentally friendly. Compared to other thermal joining procedures, it saves 75% of total energy consumption. This is due to its low energy requirement, which is specifically applied to the joint area and only during the actual weld time. A great deal of importance has been placed on energy efficiency for the latest generation of ultrasonic generators, ULTRAPLAST. The generators work with an extremely high degree of efficiency, more than 88% when loaded. An automatic energy save mode has been implemented in the machine type HiQ DIALOG, which automatically disconnects the machines from the compressed air supply during idle time and avoids unnecessary control air consumption and other leaks. It's technology that's also kind to the environment.

## DIALOG G4

The fourth generation of weld process software is proof of Herrmann Ultraschall's capacity for innovation. DIALOG G4 is a superior piece of software for controlling and operating the weld process and machine functions. Graphic visualization of the weld process allows for intelligent parameter optimization to maximize weld quality. A unique SoftTouch mode prevents damage to the joint geometry when the sonotrode descends on the part. Force profiling and collision monitoring are other features which guarantee a high-quality and safe weld process. To make the most effective use of the software, operators can choose between EasySelect mode for beginners and an expert mode. Suitable modular add-ons expand DIALOG G4's range of functions.



## ULTRAPLAST digital

A digital generator technology specially configured for fast intermittent welding of thermoplastic parts. The new generators are available in frequencies of 20 kHz, 30 kHz and 35 kHz with a wider output spectrum from 900 W to 6200 W. Thanks to a new chassis and cooling concept, the generators are suited to extreme operating conditions.



## ActiveGuard safety concept

With its sophisticated safety concept, Herrmann Ultraschall guarantees complete operational safety for the operator. Open protective equipment is monitored by safety prompts. On all machines the ActiveGuard concept with ergonomic 2-hand activation provides highest operational safety. Potential crushing and danger areas are eliminated for further operator safety. The ActiveGuard concept complies with EN13849 based on the Machinery Directive 2006/42/EG.



**Welded with ultrasonic technology**  
**from Herrmann Ultraschall.**



# Ultra<sup>3</sup>

BY HERRMANN ULTRASCHALL

- ✓ **ULTRA** PRECISE
- ✓ **ULTRA** FLEXIBLE
- ✓ **ULTRA** ECONOMICAL



**WH** **Herrmann**  
Ultraschall



**FIRST CLASS TECHNOLOGY. WORLDWIDE.**

**Global Headquarters**

**Herrmann Ultraschalltechnik GmbH & Co. KG**

Descostastraße 3–9 · 76307 Karlsbad, Germany

[www.herrmannultraschall.com](http://www.herrmannultraschall.com)

**North American Headquarters**

**Herrmann Ultrasonics, Inc.**

1261 Hardt Circle · Bartlett, IL 60103, USA

[www.herrmannultrasonics.com](http://www.herrmannultrasonics.com)

**China Headquarters**

**Herrmann Ultrasonics (Taicang) Co. Ltd.**

Build 20-B, No. 111, North Dongting Road, Taicang,

Jiangsu Province, China · [www.herrmannultrasonic.cn](http://www.herrmannultrasonic.cn)

**Japan Headquarters**

**Herrmann Ultrasonic Japan Corporation**

KOIL 503-1, 148-2 Kashiwanoha Campus, 178-4 Wakashiba,

Kashiwa City, Chiba 277-8519 · [www.herrmannultrasonic.co.jp](http://www.herrmannultrasonic.co.jp)

